

Steerables®

Wall Mounting System

The SAS-100-20 is an efficient, load rated universal wall arm system for objects, such as, loudspeakers and video mounts weighing up to 100 lb./45.5 Kg. Loudspeaker and video monitor mounts can easily be attached and aimed from walls and other vertical structures with ease of installation and flexibility in adjustment.

This all structural steel alloy assembly is ready to accommodate most theatrical yoke mounts. The SAS-100-20 comes with hardware and is available in a black, baked-on powder coat finish.

For optimum application confidence, this mount has been load-tested to ten times its normal working load without achieving ultimate failure.

DIMENSIONS:

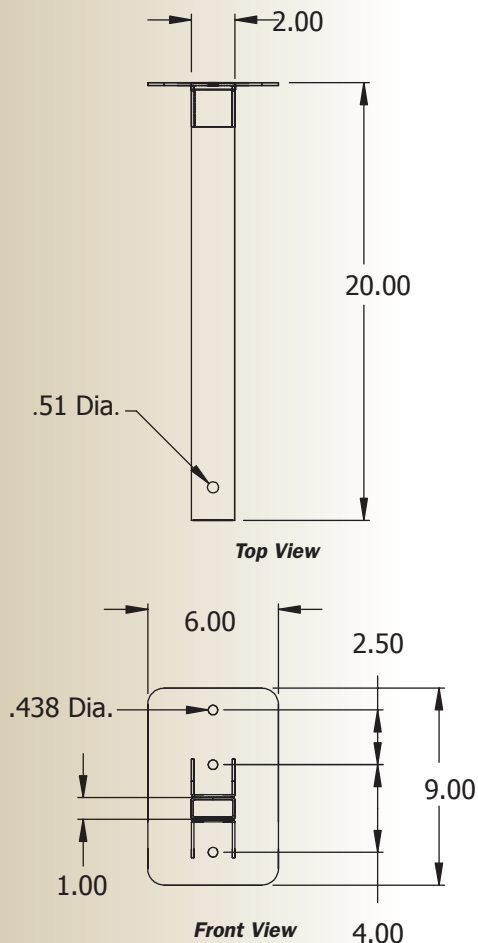

Hardware for mounting to the wall structure is not included.

STANDARD FEATURES:

- Accommodates loudspeaker, lighting and theatrical yoke mounts
- Mounts to walls and other structural surfaces
- Minimal wall surface area required
- Significant reductions in installation and planning time
- Adapts to many standard Yoke and U-Series assemblies

SPECIFICATIONS:

Material:	Alloy steel tube and plate
Finish:	Powder coat
Color:	Textured black
Working load limit:	100 lbs./45 kg.
Design factor:	10:1 ratio based on ultimate yield point
Net weight:	4.5 lbs./2.05 kg.
Shipping weight:	5.5 lbs./2.5 kg.
Pack count:	1 unit/carton

PACKAGE CONTENTS:

1 pc.	Wall arm
1 pc.	Hardware kit

OPTIONAL STUD ADAPTER:

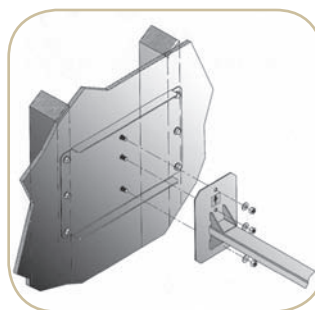

WARNING: Mounting and/or suspension of audio and video equipment requires experienced professionals. Improperly installed equipment can result in property damage, personal injury and/or liability to the installing contractor.



MADE IN THE USA

ALWAYS USE SAFETY CABLES.



A division of:
ADAPTIVE TECHNOLOGIES GROUP
 1635 E. Burnett Street
 Signal Hill, CA 90755 USA
 PH: 562.424.1100 FX: 562.424.3520

www.allenproducts.com